

# Precision Shaft Alignment... laser systems Seminar Synopsis

---

## Precision Shaft Alignment...laser systems

Laser alignment systems are becoming more and more prevalent throughout industry. Over a half dozen different computerized laser systems are available in today's market for performance of shaft alignment and other precision measurement tasks. While each of the available systems has its own specific operating principles, advantages, and limitations, all of them offer high degrees of accuracy and help make alignment processes very efficient.

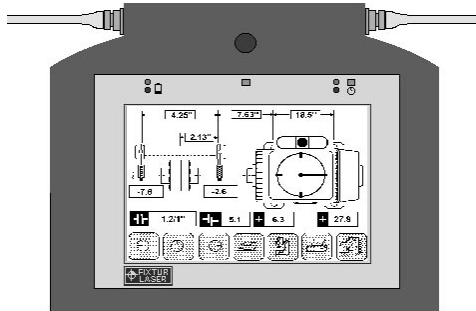
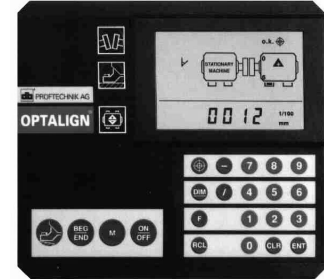

However, much too often these instruments are purchased and given to field technicians who lack the knowledge of fundamental alignment concepts and the dial indicator alignment processes on which all laser system software programs are based. Companies who attempt to implement use of laser alignment systems without providing field technician's sound training are too often disappointed in the returns from their investment.

This seminar focuses on specific procedures for using today's laser alignment systems and the fundamental concepts and skills required to perform precision alignment. UniTech's unique approach provides students not only with an understanding of the specific procedure to follow for the laser system being used, but also the foundation to understand why and how the system works the way it does.

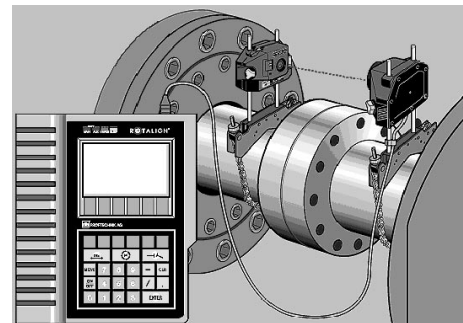

Detailed procedures for use of specific laser systems, including the Optalign<sup>®</sup>, Combi-Laser<sup>®</sup>, Rotalign<sup>®</sup>, Fixturlaser Shaft 100<sup>®</sup>, Hamar<sup>®</sup>, and UltraSpec<sup>®</sup>, are addressed based on client needs. Supporting information in fundamental alignment concepts, dial indicator alignment processes, and special alignment procedures are also addressed based on needs. Up to 50% of this seminar consists of guided hands-on alignment activities

# Precision Shaft Alignment...

## laser systems

## Seminar Synopsis

---

---

### Who should attend?

This seminar is designed primarily for maintenance, engineering, technical support and management personnel whose job functions involve alignment of rotating machinery. The scope of content is appropriate for those who align machines, those who detect, investigate and resolve premature machinery failure problems due to misalignment, as well as those who direct activities relative to alignment and machine reliability.

### Highlights

In this seminar, you will gain knowledge and experience relating to:

- Maximizing Machinery Reliability
- Fundamentals of Shaft Alignment
- Use of Specific Laser Systems
- Proactive Base-bound and Bolt-bound Solutions
- Dealing with Dynamic Movement
- Use of Special Laser System Programs and Features
- Hands-on Activities on all Subjects

# Precision Shaft Alignment...

## laser systems

### Seminar Synopsis

---

#### Task Description

Align two coupled rotating machinery shafts to specified tolerances using a specific laser alignment system(s), including proper planning, rough and precision alignment per approved procedures.

#### Elements:

1. Properly plan the task.
2. Perform pre-alignment machinery inspections and corrections.
3. Perform rough alignment of shafts (if needed).
4. Properly setup alignment hardware.
5. Obtain valid misalignment data.
6. Interpret data to determine vertical and horizontal offset and angularity.
7. Determine corrections needed.
8. Make corrections.
9. Obtain and interpret new data.
10. Compare results to tolerances.
11. Repeat steps 5 - 10 until tolerances are satisfied.
12. Troubleshoot common laser alignment problems.

#### Prerequisites:

1. Demonstrate an understanding of the importance of precision alignment and the adverse effects of excessive misalignment on machinery reliability.
2. Demonstrate an understanding of the following fundamentals of shaft alignment:
  - A. Alignment Terminology
  - B. Types, Forms, and Planes of Misalignment
  - C. Elements of Effectively Performing Precision Alignment Tasks
  - D. Pre-alignment Machinery Inspections and Corrections
3. Demonstrate an understanding of fundamental rim-face and reverse dial indicator alignment processes.

#### Related Tasks:

1. Use the rim-face and reverse dial indicator methods to perform precision shaft alignment of two (2) coupled horizontal rotating machines.
2. Perform precision shaft alignment of horizontal rotating equipment that is subject to dynamic movement.
3. Perform precision shaft alignment of three (3) or more coupled horizontal rotating machines.
4. Perform precision shaft alignment of two coupled vertical rotating machines.

# Precision Shaft Alignment...

## laser systems

### Seminar Synopsis

---

---

#### Seminar Objectives

Upon completion of this training the student will be able to properly:

#### Alignment Fundamentals

1. Explain the importance of precision alignment, including some adverse effects of misalignment on machinery life and energy consumption.
2. Define shaft alignment, rotational centers, misalignment and other key alignment terms.
3. Explain how shaft offset and angular misalignment conditions are properly described and documented.
4. Explain the following three major phases of alignment tasks:
  - A. Planning and Pre-alignment
  - B. Rough Alignment
  - C. Precision Alignment
5. Explain the effects of pre-alignment considerations on the overall alignment process and/or the machines' operation.
6. Properly perform pre-alignment checks.
7. Identify and explain the general types of soft foot and how to detect and correct soft foot conditions.
8. Explain the effects of soft foot conditions on the alignment process and on machine operation.
9. Explain and demonstrate how to properly perform rough alignment of coupled machines.
10. Explain the general advantages, disadvantages, and sources of error associated with each of the following alignment methods:
  - A. Straight Edge/Thickness Gauge Methods
  - B. Rim-Face Dial Indicator Methods
  - C. Reverse Dial Indicator Methods
  - D. Laser Systems
11. Explain the general effects of thermal growth on alignment processes and machine operation.

# Precision Shaft Alignment...

## laser systems

### Seminar Synopsis

---

---

#### **Overview of Today's Laser Systems**

12. Explain the basic operation and major components of each of the following laser alignment systems, including the different software programs and key features of each:
  - A. Pruftechnik Optalign VP
  - B. Fixturlaser Combi
  - C. CSI Ultraspec
  - D. Pruftechnik Rotalign
  - E. Fixturlaser Shaft 100
13. Briefly explain how each laser system is used for alignment of machines with horizontal shafts.
14. Briefly explain how laser systems are used for measurement of straightness, flatness, and parallelism.

#### **Optalign, Combi, Ultraspec, Fixturlaser Shaft 100/200 and Rotalign Horizontal Shaft Alignment**

15. Identify and explain the function and key features of each component in a specific laser system.
16. Install brackets and setup laser system components.
17. Describe the function of each computer key on a specific laser system.
18. Measure and enter required machine dimensions.
19. Obtain a valid set of alignment measurements, including:
  - A. Adjusting beam position.
  - B. Use of one or more laser system measurement modes.
  - C. Interpreting on-screen instructions and symbols.
  - D. Checking measurements sets for repeatability.
20. Explain the laser system's different measurement mode options, including the applications, advantages, and disadvantages of each.

# Precision Shaft Alignment...

## laser systems

### Seminar Synopsis

---

---

21. View and interpret results of alignment measurements, including:
  - A. Accessing vertical and horizontal data.
  - B. Determination of amount and direction of required moves.
  - C. Interpreting on-screen instructions and symbols.
  - E. Selection of tolerance table options (if applicable.)
  - F. Evaluation of displayed values for angularity and offset.
  
22. Utilize machine move monitoring functions, including:
  - A. How to enter and exit the move mode.
  - B. Determining directions of required moves.
  - C. Determining when shaft positions are within tolerances.
  
23. Obtain a set of soft foot measurements using laser and conventional soft foot measurement methods..
  
24. Utilize the laser system's file storage and print functions, including:
  - A. Saving a file.
  - B. Naming a file.
  - C. Configuring a printer.
  - D. Printing screens and reports.
  
25. Describe the laser system's power supply and power management functions, including:
  - A. When to change batteries.
  - B. How to detect impending battery failure.
  
26. Describe key accessories of the laser system, including:
  - A. Optional brackets
  - B. Cable options
  - C. Battery options
  - D. Software options

# Precision Shaft Alignment...

## laser systems

### Seminar Synopsis

---

---

#### Laser System Special Procedures

27. Configure and setup laser system software.
28. Describe how the laser system indicates that measurement values are not valid and corrective actions.
29. Change which machine feet are designated as static.
30. Enter and evaluate target values and thermal growth amounts, including:
  - A. How to interpret the meaning of "+" and "-"
  - B. How to interpret specified values.
  - C. Effect of values on the measurement and alignment data.
31. Use the laser system to align two coupled machines vertical shafts.

# Precision Shaft Alignment...

## laser systems

## Seminar Synopsis

---

---

### Seminar Schedule

#### Day 1 Subjects

- Introduction
- Maximizing Machinery Reliability Overview
- Review of Shaft Alignment Fundamentals
- Pre-alignment Procedures
- Laser Alignment Systems Overview

#### Day 2 Subjects

- Horizontal Machine Alignment Fundamental Processes
  - Setting Up the Laser System
  - Measuring and Entering Dimensions
  - Obtaining Measurements
  - Interpreting Results
  - Making Moves
  - Alignment Completion
- Dealing with Base Bound and Bolt Bound Conditions

#### Day 3 Subjects

- Horizontal Machine Alignment Processes Continued
- Horizontal Machine Alignment Special Processes
  - Advanced Configuration and User Setup
  - Using Other Measurement Modes
  - Tables and Tolerances
  - Data Management
  - Laser Soft Foot Programs

#### Day 4 Subjects

- Dealing with Dynamic Movement
- Thermal Growth and Target Specifications Overview
- Vertical Machine Alignment Processes
- Use of Lasers for Machine Trains
- Conclusions

**NOTE: Approximately 50% of this seminar consists of guided hands-on activities!**