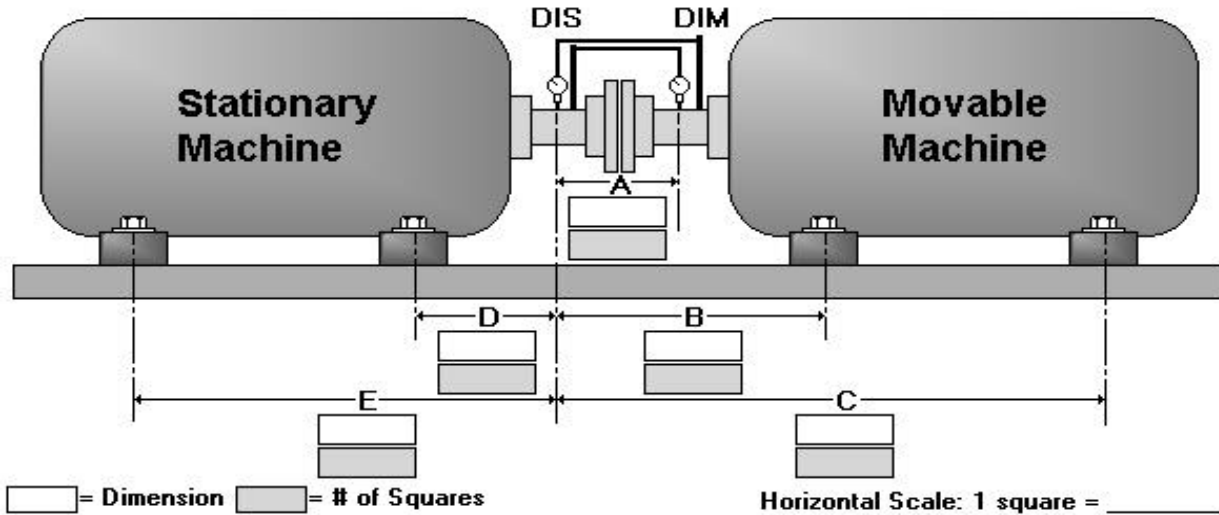

Reverse Dial Indicator Alignment Recording Form

Equipment ID:		Location:	
Stationary Machine:		Movable Machine:	
Performed By:		Date:	

Machine Dimensions:

Indicator Fixture Sag:

Dial Indicator on Stationary (DIS):	Dial Indicator on Movable (DIM):
--	---

Reverse Dial Readings:
Direction of View: Face the Stationary Machine

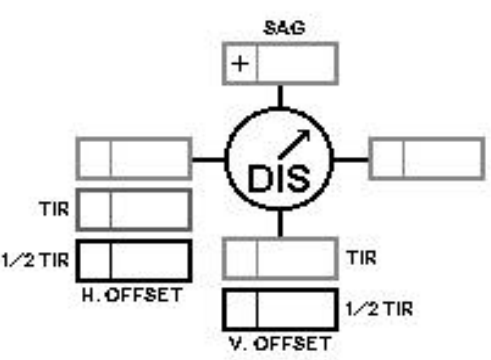
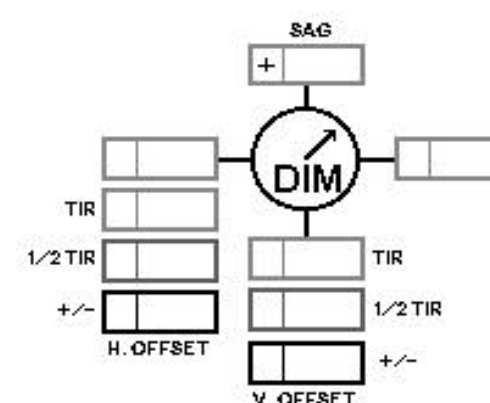
Set # 1

	
---	--

NOTES:

1. Compensate for sag by "dialing in" the amount of indicator bar sag as a positive value at 12:00 position on both dials. Sag does not effect the accuracy of horizontal rim readings.
2. For vertical and horizontal rim readings, shaft offset is 1/2 of the Total Indicator Reading (TIR).
3. Always change the sign of the DIM values to compensate for "reversed" readings. For valid dial readings, the sum of 12:00 and 6:00 values equals the sum of 3:00 and 9:00 values.

Set # :

Reverse Dial Indicator Alignment Recording Form

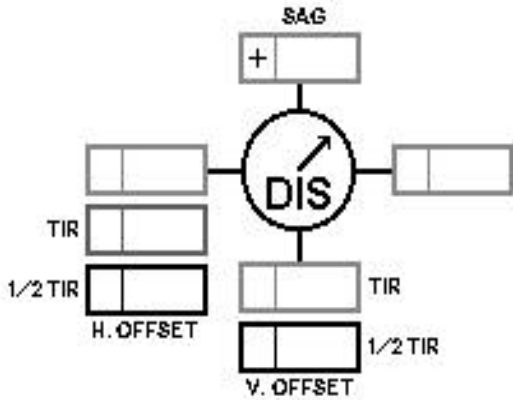

Diagram for DIS (Dial Indicator) alignment recording. The central circle contains 'DIS' and an arrow pointing up and to the right. It is connected to a 'SAG' box with a '+' sign above it. To the left, there are three boxes: 'TIR' (top), '1/2 TIR' (middle), and 'H. OFFSET' (bottom). To the right, there are three boxes: 'TIR' (top), '1/2 TIR' (middle), and 'V. OFFSET' (bottom). Each box is divided into two sections for recording data.

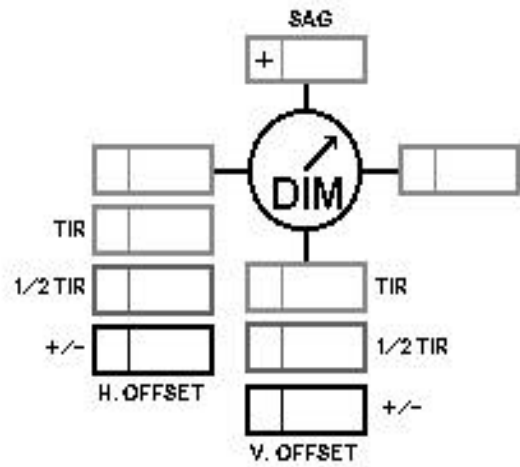

Diagram for DIM (Dial Indicator) alignment recording. The central circle contains 'DIM' and an arrow pointing up and to the right. It is connected to a 'SAG' box with a '+' sign above it. To the left, there are three boxes: 'TIR' (top), '1/2 TIR' (middle), and 'H. OFFSET' (bottom). To the right, there are three boxes: 'TIR' (top), '1/2 TIR' (middle), and 'V. OFFSET' (bottom). Each box is divided into two sections for recording data.

Set # :

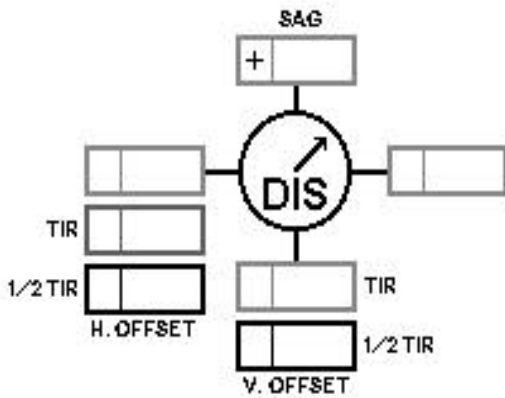

Diagram for DIS (Dial Indicator) alignment recording. The central circle contains 'DIS' and an arrow pointing up and to the right. It is connected to a 'SAG' box with a '+' sign above it. To the left, there are three boxes: 'TIR' (top), '1/2 TIR' (middle), and 'H. OFFSET' (bottom). To the right, there are three boxes: 'TIR' (top), '1/2 TIR' (middle), and 'V. OFFSET' (bottom). Each box is divided into two sections for recording data.

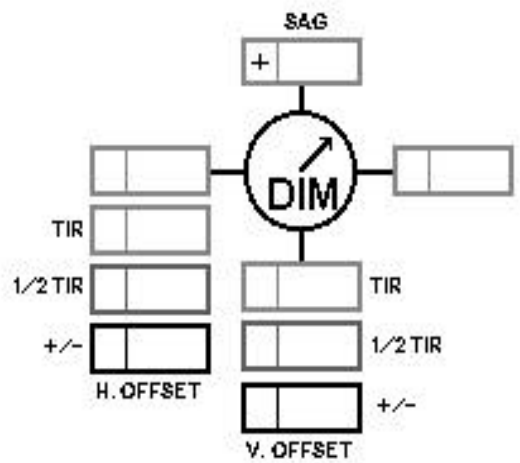

Diagram for DIM (Dial Indicator) alignment recording. The central circle contains 'DIM' and an arrow pointing up and to the right. It is connected to a 'SAG' box with a '+' sign above it. To the left, there are three boxes: 'TIR' (top), '1/2 TIR' (middle), and 'H. OFFSET' (bottom). To the right, there are three boxes: 'TIR' (top), '1/2 TIR' (middle), and 'V. OFFSET' (bottom). Each box is divided into two sections for recording data.

Set # :

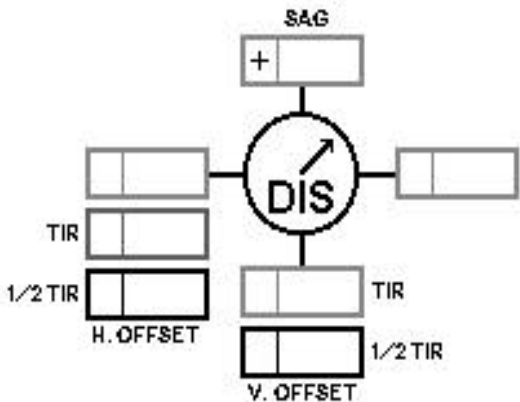

Diagram for DIS (Dial Indicator) alignment recording. The central circle contains 'DIS' and an arrow pointing up and to the right. It is connected to a 'SAG' box with a '+' sign above it. To the left, there are three boxes: 'TIR' (top), '1/2 TIR' (middle), and 'H. OFFSET' (bottom). To the right, there are three boxes: 'TIR' (top), '1/2 TIR' (middle), and 'V. OFFSET' (bottom). Each box is divided into two sections for recording data.

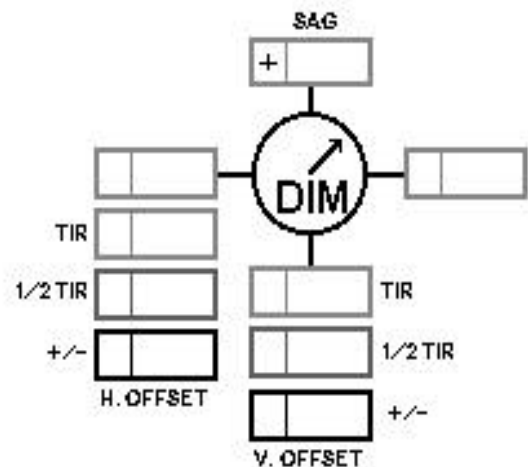

Diagram for DIM (Dial Indicator) alignment recording. The central circle contains 'DIM' and an arrow pointing up and to the right. It is connected to a 'SAG' box with a '+' sign above it. To the left, there are three boxes: 'TIR' (top), '1/2 TIR' (middle), and 'H. OFFSET' (bottom). To the right, there are three boxes: 'TIR' (top), '1/2 TIR' (middle), and 'V. OFFSET' (bottom). Each box is divided into two sections for recording data.